

Big Bright & Beautiful

Breakthrough large scale
display technology

- Seamless LCD tiling to any scale
- High brightness to 2000 nit
- Sunlight rejection technology
- Unprecedented resolution and close up viewing quality for a bright, large scale screen.
- Hantarex International/ ITrans displays are available in modular or fixed formats to suit a wide range of applications.

 **HANTAREX**
ELECTRONIC SYSTEMS



Flight No.	Destination	Scheduled	Status
1234	LONDON	07:00	On Time
5678	PARIS	08:30	Delayed
9101	NEW YORK	09:15	On Time
2345	TOKYO	10:00	On Time
6789	SINGAPORE	11:30	On Time
0123	AUSTRALIA	12:00	On Time
4567	AFRICA	13:00	On Time
8901	ASIA	14:00	On Time
2345	EUROPE	15:00	On Time
6789	AMERICA	16:00	On Time
0123	AFRICA	17:00	On Time
4567	ASIA	18:00	On Time
8901	EUROPE	19:00	On Time
2345	AMERICA	20:00	On Time
6789	AFRICA	21:00	On Time
0123	ASIA	22:00	On Time
4567	EUROPE	23:00	On Time
8901	AMERICA	00:00	On Time
2345	AFRICA	01:00	On Time
6789	ASIA	02:00	On Time
0123	EUROPE	03:00	On Time
4567	AMERICA	04:00	On Time
8901	AFRICA	05:00	On Time
2345	ASIA	06:00	On Time



TEXT 65665
AND YOUR
FLIGHT NUMBER
TO GET YOUR
FLIGHT TIME

Scalability + Visibility = Possibility

ITrans Displays

Hantarex International offer a unique display proposition, ITrans, which for the first time enables high resolution, large format and sunlight readable displays.

ITrans Modular displays utilise all the benefits of proven LCD capabilities and use Screen Technology's ITrans tile - a fibre optic front plate which brings significant benefits to existing displays.

This front plate offers sunlight rejection technology which significantly reduces glare ensuring your digital signage projects always stand out.

The patented ITrans tile magnifies the image from LCD panels, illuminated by fluorescent lamps to form a very bright, seamless tiled display that is completely scalable, offering a range of high resolution formats.

ITrans Modular offers up to 2000 cd/m² and an impressive pixel pitch of 1.7mm, making it viewable near or far and also offering high brightness and high resolution, something that traditional displays cannot match.

ITrans Modular can be built into an infinite variety of large format sizes and aspect ratios.

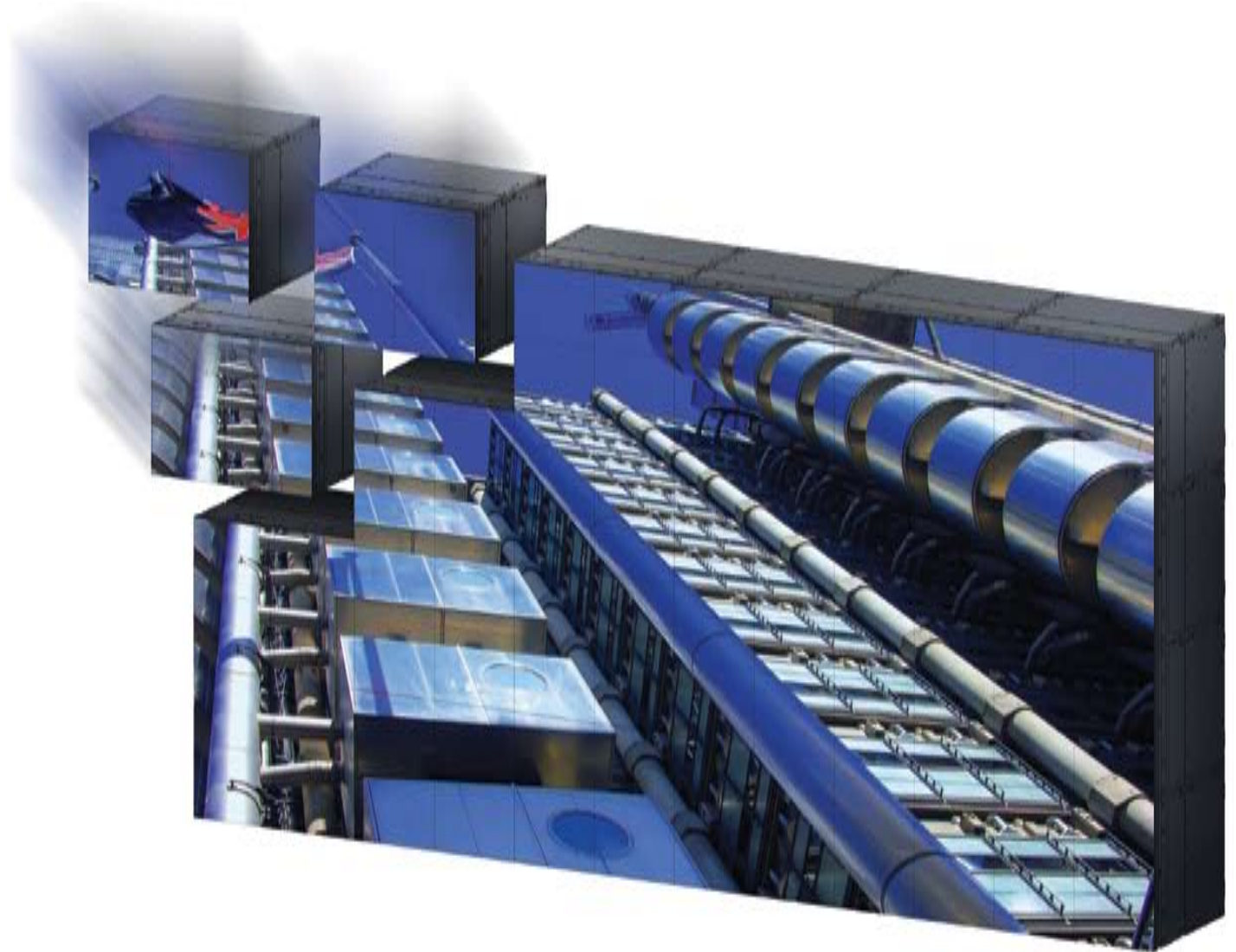

Scalability + Visibility = Possibility

ITrans - Fixed and Modular Product Options

Advertising Formats

For example, outdoor enclosed 6 sheet.

ITrans Tiles

Ideal for OEM Use.

ITrans Modular

34" diagonal self contained module for on site installation to wide variety of formats.

ITrans Fixed Format

45", 62", 80" - landscape or portrait. Other sizes available on request.

ITrans - Key Characteristics

- Displays images that have fine details, crisply and clearly. 1.7mm pixel pitch
- Each 1.7mm pixel is full colour, full fill (over 90% fill factor) allowing excellent close viewing.
- Excellent moving video and still image quality
- Can be flexible in shape - long, short, wide or narrow
- Can be viewed at any distance - near or far - with no loss of picture quality or impact.
- High Brightness - daylight readable even in high ambient light conditions.

ITrans Benefits

Resolution

- High resolution
- Full colour video quality
- No minimum viewing distance
- High quality text & images.

Brightness

- High luminance - 2000 cd/m²
- Viewable in high ambient light areas
- Sunlight Rejection Technology.

Size and Format

- Any size from 34" diagonal to 300" & more.
- Flexible build shape
- Modular & Fixed Format options
- Portrait & landscape options
- Columnar displays available

ITrans Modular

The latest in the development of the ITrans concept.

The base element is a 34" 'building block' which can be assembled to make screens of any shape or size, which are larger compared with LCD and Plasma and exceed LED resolution.

ITrans - Applications & Possibilities...

Transport

Mixing travel information with advertising.

Retail Outlets

For 'through the window' advertising.

Exhibitions

Replacing conventional flat panel displays.

Hospitality & Entertainment

Ideal for bright sports venues and stadiums.

Corporate Atriums

A bright display for modern atriums.

ITrans



High Brightness 1000 nit LCD

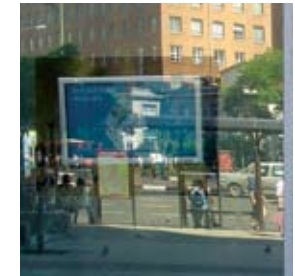

Not a simulated image - both photographs taken in the same location under high ambient light conditions

ITrans



Upto 91% Pixel Fill

LED



Less Pixels Per Unit Area

Scalability + Visibility = Possibility

An ITrans Module consists of four ITrans tiles, LCD's, custom high brightness backlight and electronics in an easy to use and self contained 34" diagonal module

ITrans Modular - Technical Specification Per 34" Module	
Width	691.6mm
Height	515.2mm
Diagonal	34" nominal (863.6mm)
Depth	300mm
Format	Landscape or Portrait
Weight	40kg
Mounting	Free standing on suitable surfaces or wall hung with external frame
Maintenance	Easy access to all active components for inspection or in-situ replacement, via rear panel
Resolution	408 x 304
Pixel Size	1.7mm x 1.7mm with 91% fill factor. ITrans offers a fill factor 2 to 3 times that of any existing LED product
Pixel Structure	No sub-pixelation
Number of Colours	16.7 million
Response Time	8ms
Brightness	2000 cd/m ²
Aspect Ratio	All standard aspect ratios are achievable with ITrans Modular
Video Source	VGA, Composite, PAL/NTSC, RGB, SDI, S VHS and YUV through external electronic interface
Power Supply	Single Phase, 220-240 V AC
Power Consumption	200 - 700W Per Module Dependant on Brightness Settings
Operating Temperature Range	5°C to 25°C
Storage Temperature Range	-20°C to +40°C
Operating Humidity Range	20% to 85% Non Condensing
Storage Humidity Range	5% to 90% Non Condensing

Comparison of large area display technologies						
	LCD	Plasma	Rear Projection Cubes	LED 6mm	LED 3mm	ITrans
Typical Pixel Pitch	0.75mm	1.05mm	1.3mm	6mm	3mm	1.7mm
Full Colour	†✓✓†	✓✓	✓✓	✓	✓	✓✓
Video and Text	✓	✓	✓	✓	✓	✓
Low Profile	✓✓	✓✓		✓	✓	✓
Sunlight Readable	✓			✓✓	✓	✓✓
Usable for Displays >106" Diagonal			✓	✓	✓	✓
High Resolution	✓	✓	✓			✓
Usable From Close Range (<5m)	✓	✓	✓			✓
Flexible Format			✓	✓	✓	✓
Mullions (mm)	Wide	Wide-Medium	Narrow	None	None	None

✓ = Suitable ✓✓ = Highly Suitable

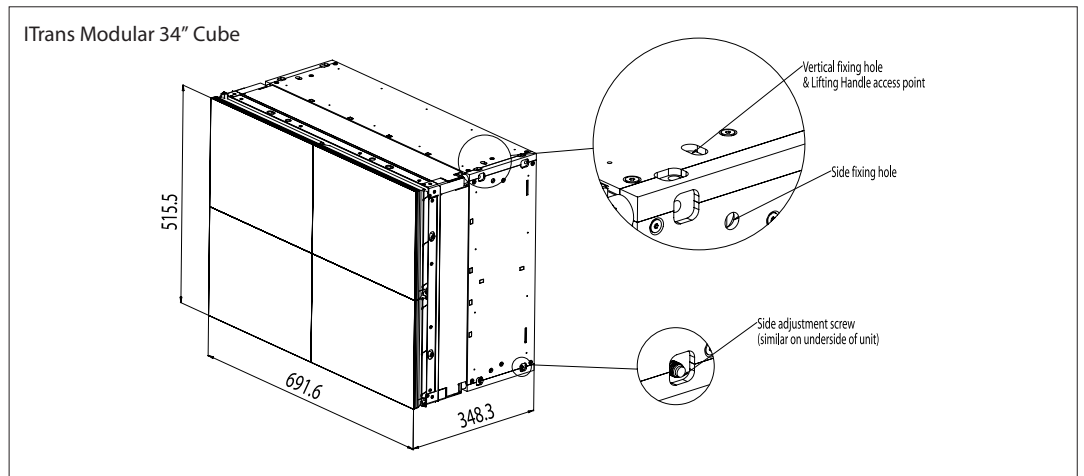

Hantarex International Limited

Unit 7, 243 Kangley Bridge Road, Sydenham, London, United Kingdom

T +44 (0) 20 8778 1414 F +44 (0) 20 8659 9348

W www.hantarex.com

E sales@hantarex.com